

Q.TÀ SCATOLA PACKAGE Q.TY	50
PESO SCATOLA PACKAGE WEIGHT	15 kg 33.075 lbs
DIMENSIONI SCATOLA PACKAGE DIMENSION	22x35x22 cm 8.66x13.78x8.66 inches

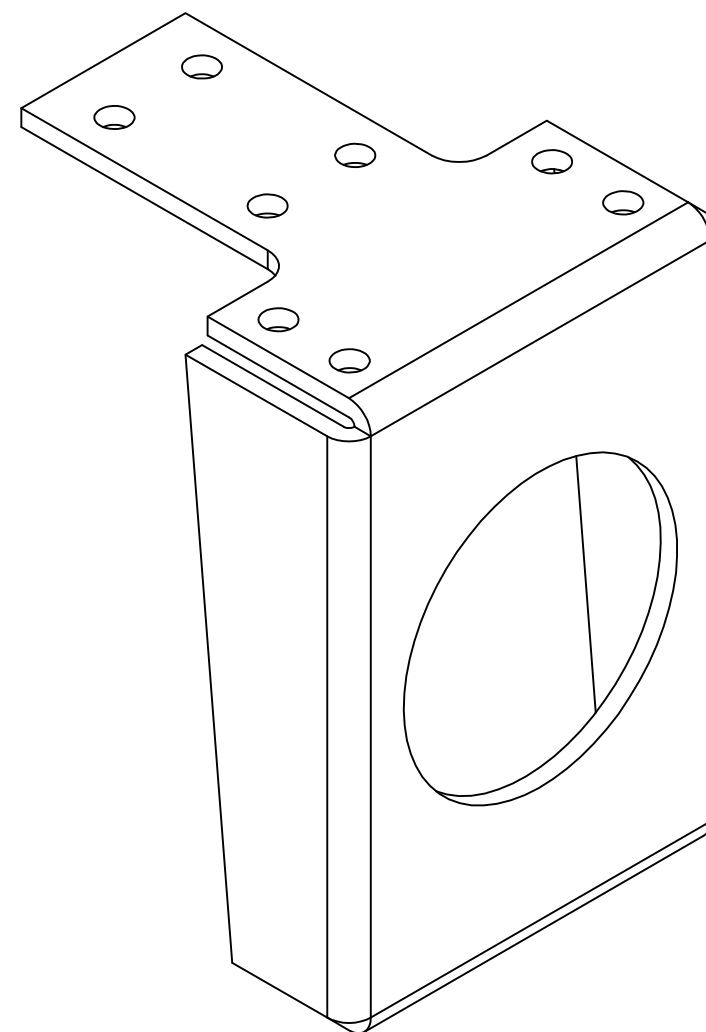

DESCRIZIONE PIEDINO IN FERRO INTERMEDIO			
DESCRIPTION INTERMEDIATE MOUNTING FOOT			
MATERIALE MATERIAL	--	TRATTAMENTO TREATMENT	--
PESO TEORICO THEORETICAL WEIGHT	-- kg -- lb	NORMA TOLLERANZA STANDARD TOLERANCE	--

SCALA SCALE	1:1	DATA DATE	2009/07/18
CODICE CODE	DS105-I	FORMATO SIZE	A3

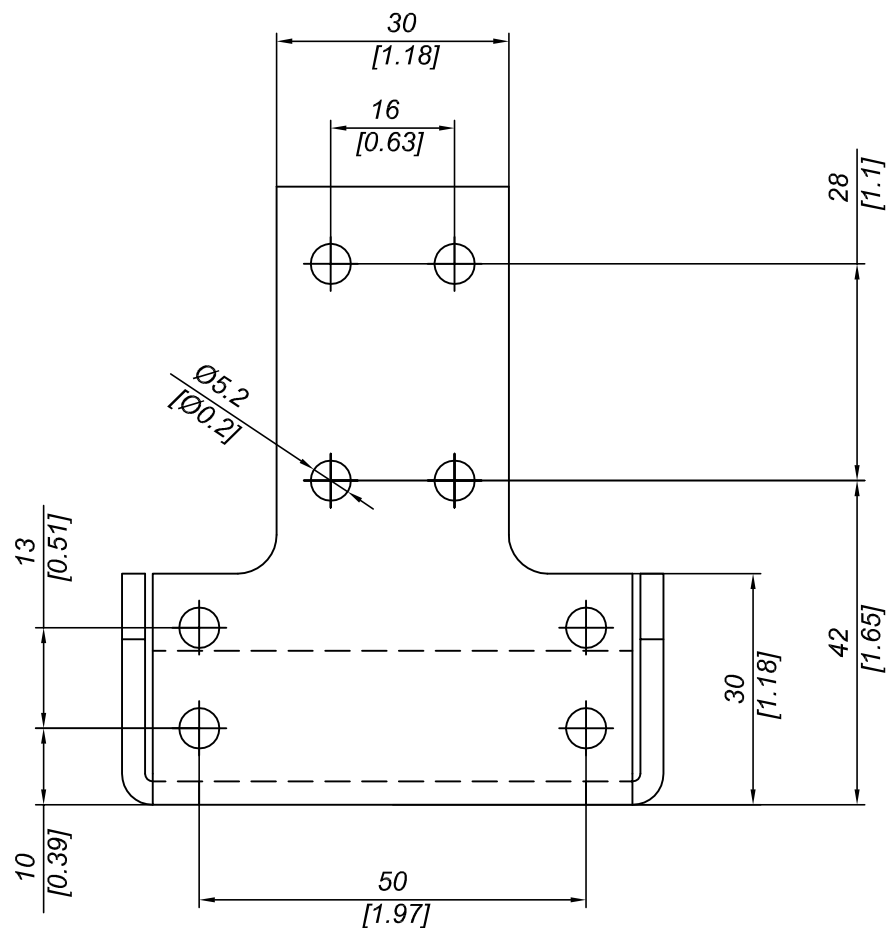
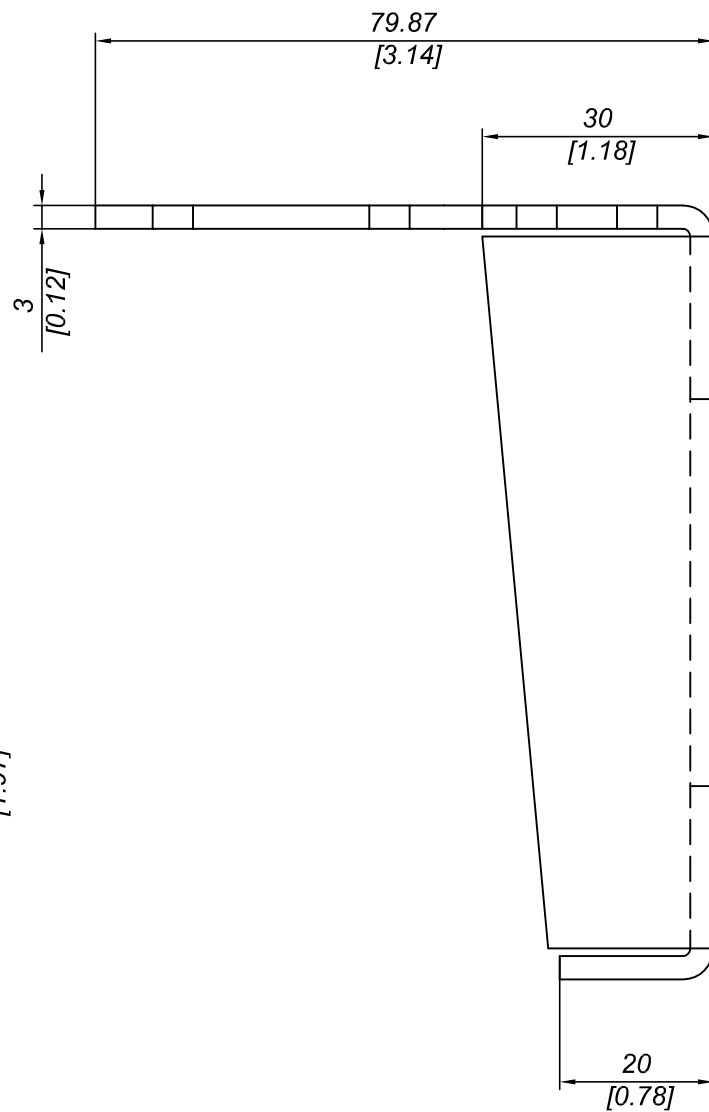
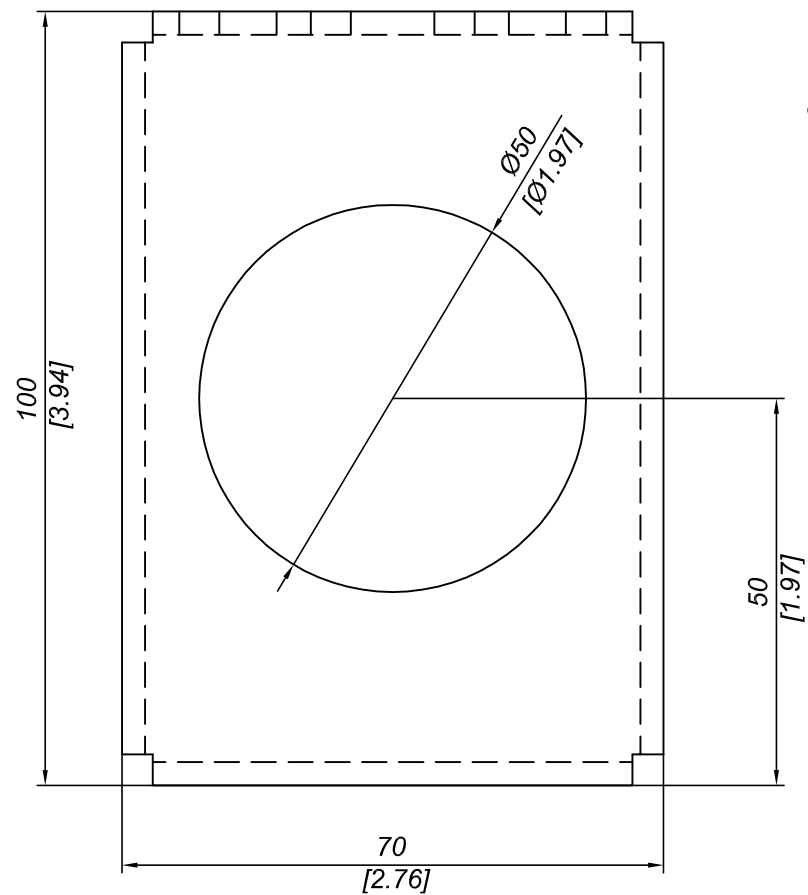
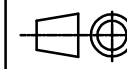

Questo disegno è di proprietà riservata alla ditta PRO-LAM ALLUMINIO s.r.l. A termini di legge è assolutamente vietato riprodurre o comunicare a terzi il contenuto del presente disegno. This drawing is a property of PRO-LAM ALLUMINIO s.r.l. This drawing shall not be reproduced or released to others except as otherwise authorized by PRO-LAM ALLUMINIO s.r.l.