

Q.TÀ SCATOLA PACKAGE Q.TY	25
PESO SCATOLA PACKAGE WEIGHT	6 kg 13.23 lbs
DIMENSIONI SCATOLA PACKAGE DIMENSION	22x35x22 cm 8.66x13.77x8.66 inches

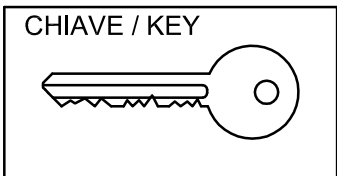

SCALA 1:2

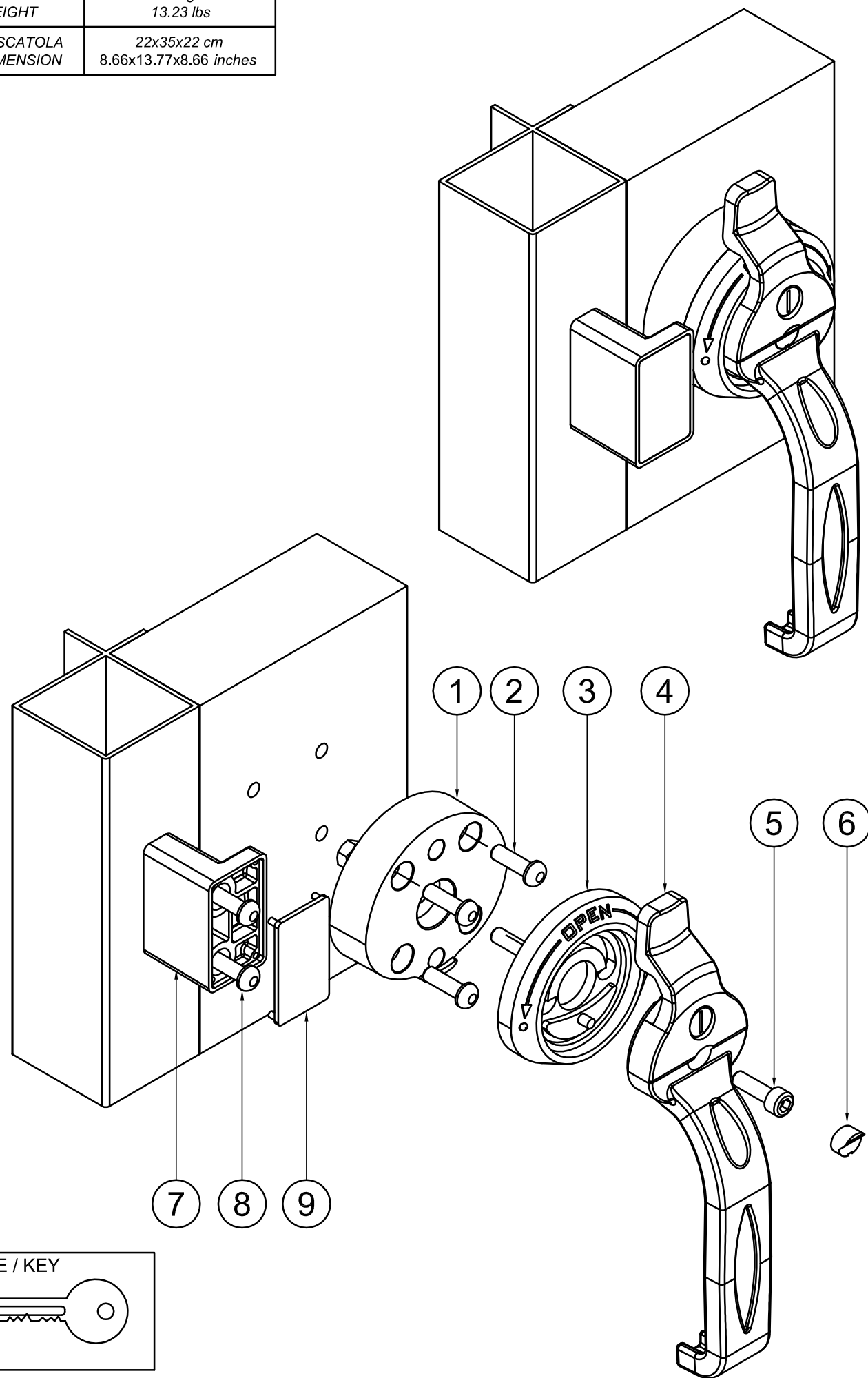
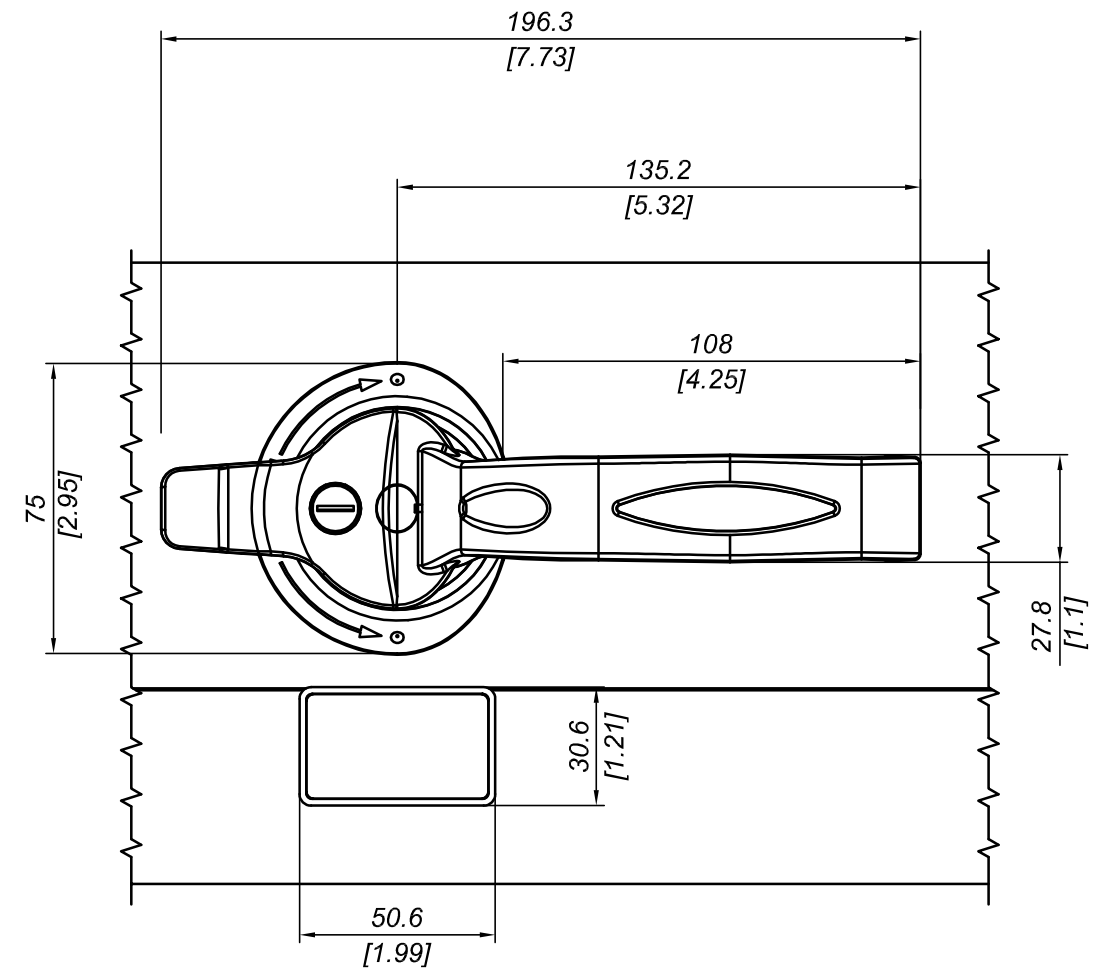

SCALA 1:3

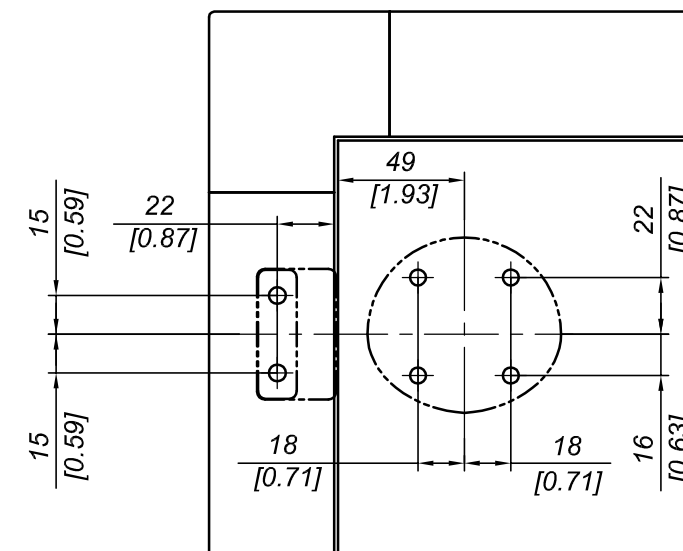

DESCRIZIONE MANIGLIA IN NYLON			
DESCRIPTION NYLON HANDLE			
MATERIALE MATERIAL	PA6 30 % FV_SV	TRATTAMENTO TREATMENT	--
PESO TEORICO THEORETICAL WEIGHT	-- kg -- lbs	NORMA TOLLERANZA STANDARD TOLERANCE	--

SCALA SCALE	1:1	DATA DATE	06/08/2009
CODICE CODE	DN ISO 0 K	FORMATO SIZE	A3

Questo disegno è di proprietà riservata alla ditta PRO-LAM ALLUMINIO s.r.l. A termini di legge è assolutamente vietato riprodurre o comunicare a terzi il contenuto del presente disegno. This drawing is a property of PRO-LAM ALLUMINIO s.r.l. This drawing shall not be reproduced or released to others except as otherwise authorized by PRO-LAM ALLUMINIO s.r.l.