

Q.TÀ SCATOLA PACKAGE Q.TY	50
PESO SCATOLA PACKAGE WEIGHT	3 kg 6.615 lbs
DIMENSIONI SCATOLA PACKAGE DIMENSION	18x25x14 cm 7.09x9.84x5.51 inches

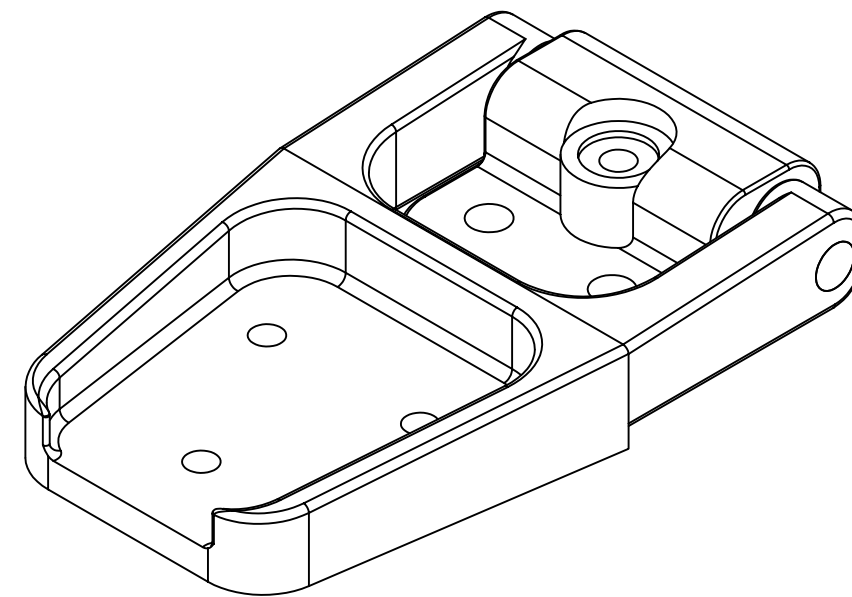
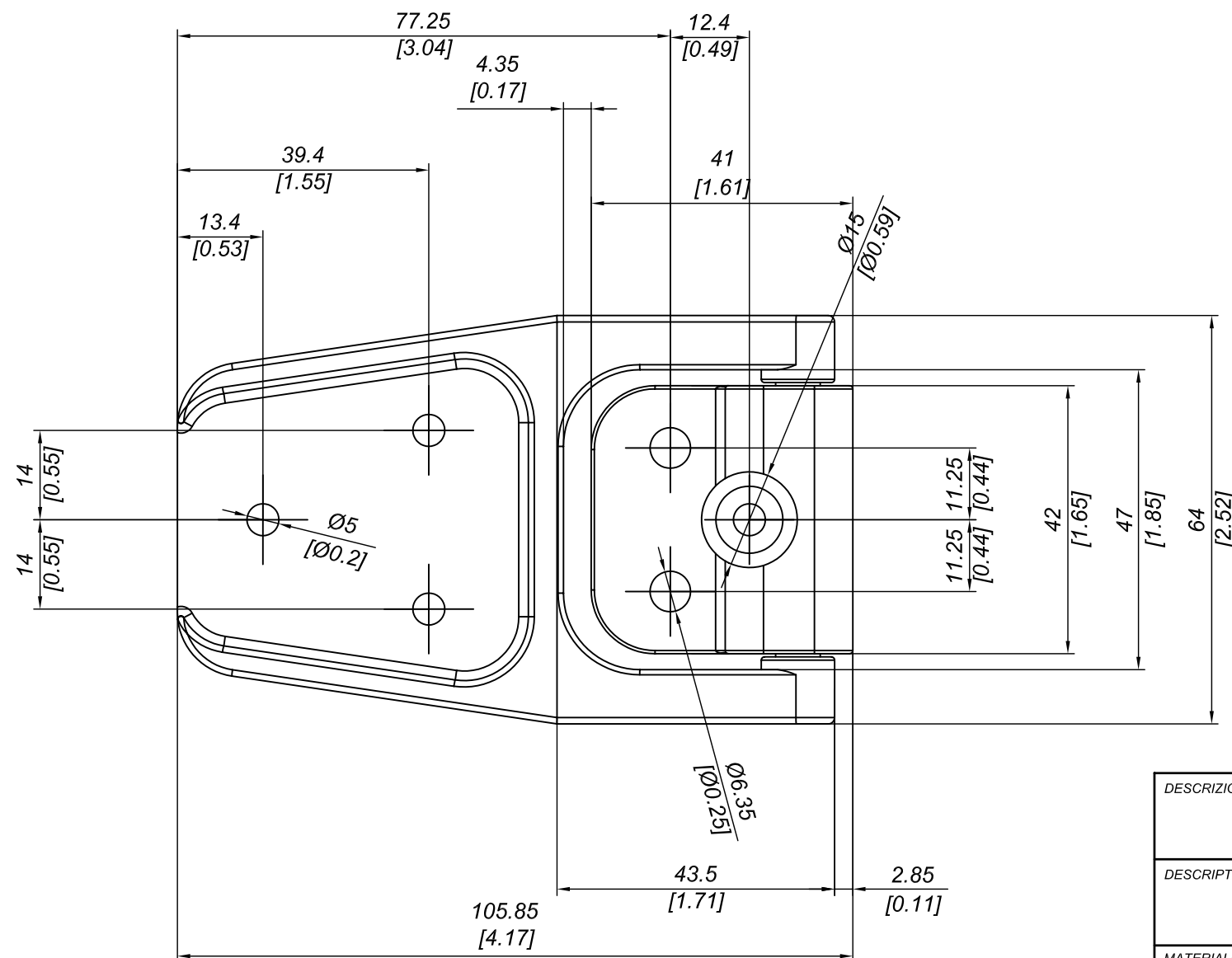
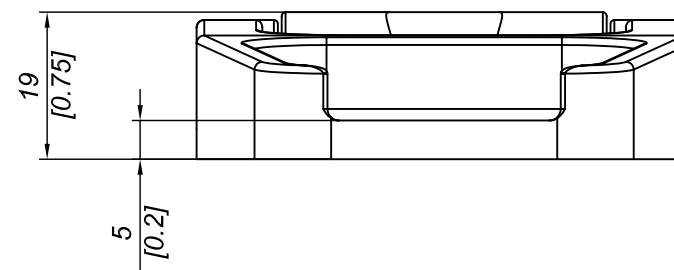
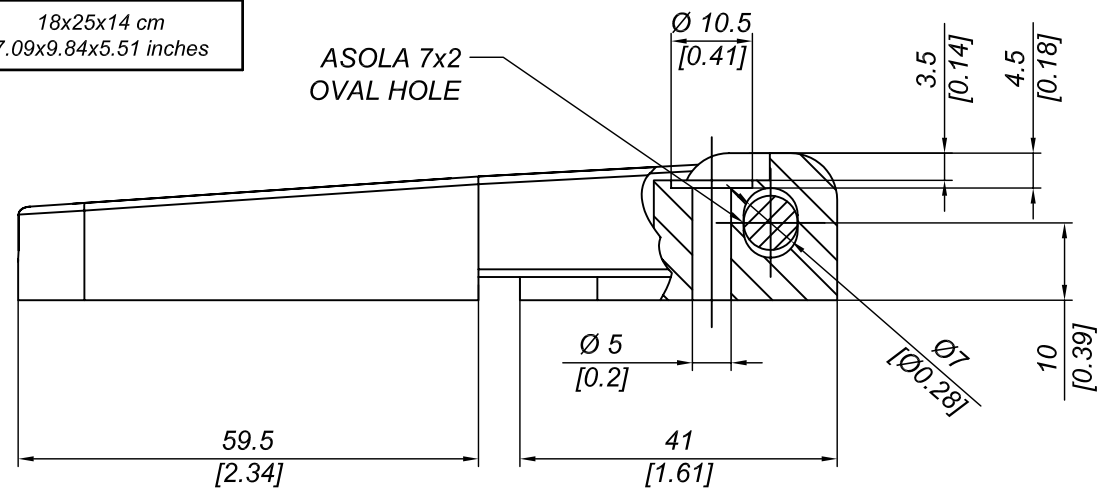

DESCRIZIONE CERNIERA CON FORO OVALE DEL PERNO		PRO-LAM s.r.l. ALLUMINIO	
DESCRIPTION HINGE WITH OVAL HOLE OF THE PIN			
MATERIALE MATERIAL	PA6+30%G.F.	TRATTAMENTO TREATMENT	--
PESO TEORICO THEORETICAL WEIGHT	-- kg -- lb	NORMA TOLLERANZA STANDARD TOLERANCE	--
SCALA SCALE		1:1	DATA DATE
CODICE CODE		N150	FORMATO SIZE

Questo disegno è di proprietà riservata alla ditta PRO-LAM ALLUMINIO s.r.l. A termini di legge è assolutamente vietato riprodurre o comunicare a terzi il contenuto del presente disegno. This drawing is a property of PRO-LAM ALLUMINIO s.r.l. This drawing shall not be reproduced or released to others except as otherwise authorized by PRO-LAM ALLUMINIO s.r.l.