

Dati prestazioni

Modello	A	-15		-10		-5		0		5		10		15		20		
		Tc	Qo	Pe	Qo	Pe	Qo	Pe	Qo	Pe	Qo	Pe	Qo	Pe	Qo	Pe	Qo	Pe
MTZ018	45	700	0.61	1050	0.69	1470	0.76	1970	0.82	2570	0.87	3270	0.91	4090	0.93	5020	0.93	
MTZ022	45	940	0.72	1370	0.81	1900	0.91	2550	0.99	3320	1.06	4240	1.11	5310	1.15	6560	1.16	
MTZ028	45	1230	0.91	1720	1.02	2350	1.13	3130	1.23	4090	1.34	5260	1.43	6650	1.51	8300	1.58	
MTZ032	45	1430	1.09	2020	1.25	2770	1.40	3690	1.54	4810	1.66	6160	1.76	7760	1.83	9630	1.86	
MTZ036	45	2050	1.29	2740	1.45	3580	1.60	4590	1.74	5780	1.86	7170	1.97	8790	2.05	10660	2.10	
MTZ040	45	2450	1.47	3160	1.61	4000	1.75	4980	1.89	6100	2.01	7390	2.12	8860	2.21	10520	2.27	
MTZ044	45	2080	1.29	2910	1.49	3940	1.67	5190	1.83	6710	1.95	8540	2.05	10710	2.13	13270	2.17	
MTZ050	45	2360	1.57	3340	1.80	4560	2.00	6040	2.17	7820	2.31	9950	2.42	12470	2.51	15410	2.57	
MTZ056	45	2290	1.64	3380	1.88	4730	2.11	6400	2.31	8420	2.49	10820	2.64	13650	2.77	16940	2.86	
MTZ064	45	2700	1.87	4010	2.17	5600	2.43	7510	2.67	9780	2.87	12440	3.04	15550	3.18	19130	3.27	
MTZ072	45	3200	2.16	4660	2.50	6430	2.81	8560	3.08	11090	3.33	14070	3.54	17540	3.74	21560	3.92	
MTZ080	45	4130	2.59	5700	2.93	7620	3.24	9950	3.54	12740	3.80	16040	4.05	19920	4.27	24430	4.48	
MTZ100	45	4660	3.25	6550	3.65	8860	4.02	11680	4.35	15050	4.63	19050	4.84	23730	4.96	29170	4.98	
MTZ125	45	5870	3.63	8230	4.17	11090	4.69	14520	5.16	18590	5.57	23380	5.89	28950	6.09	35380	6.18	
MTZ144	45	7880	4.85	10680	5.40	14060	5.94	18090	6.46	22850	6.93	28420	7.34	34870	7.67	42290	7.92	
MTZ160	45	8770	5.23	11800	5.84	15470	6.45	19890	7.06	25130	7.65	31300	8.21	38480	8.72	46760	9.18	
MTZ200	45	9320	6.50	13090	7.29	17730	8.04	23350	8.70	30100	9.26	38090	9.68	47460	9.92	58340	9.96	
MTZ250	45	11740	7.25	16460	8.35	22180	9.39	29040	10.33	37190	11.14	46760	11.77	57910	12.19	70770	12.35	
MTZ288	45	15750	9.71	21370	10.81	28130	11.89	36190	12.91	45710	13.85	56840	14.67	69750	15.35	84580	15.84	
MTZ320	45	17540	10.46	23600	11.67	30950	12.90	39780	14.11	50260	15.29	62590	16.41	76950	17.44	93530	18.37	

Modello	A	-30		-25		-20		-15		-10		-5		0		5		10		
		Tc	Qo	Pe	Qo	Pe	Qo	Pe	Qo	Pe	Qo	Pe	Qo	Pe	Qo	Pe	Qo	Pe	Qo	Pe
MTZ018	45	390	0.69	650	0.83	980	0.96	1400	1.09	1900	1.21	2520	1.31	3250	1.40	4110	1.47	5120	1.53	
MTZ022	45	640	0.86	980	1.03	1410	1.19	1960	1.34	2620	1.48	3440	1.61	4410	1.72	5550	1.82	6880	1.90	
MTZ028	45	760	1.05	1250	1.30	1850	1.53	2570	1.75	3430	1.96	4450	2.14	5640	2.31	7040	2.45	8640	2.56	
MTZ032	45	1040	1.20	1580	1.46	2240	1.71	3030	1.94	3980	2.16	5110	2.36	6440	2.55	7980	2.71	9760	2.86	
MTZ036	45	1300	1.50	1930	1.78	2690	2.06	3600	2.33	4670	2.58	5930	2.81	7400	3.01	9100	3.19	11050	3.34	
MTZ040	45	1600	1.70	2320	2.05	3160	2.37	4160	2.67	5330	2.95	6700	3.20	8290	3.44	10130	3.65	12230	3.84	
MTZ044	45	1360	1.60	2100	1.94	2990	2.25	4070	2.52	5370	2.77	6910	3.00	8740	3.20	10890	3.38	13370	3.54	
MTZ050	45	1700	1.94	2500	2.29	3510	2.62	4750	2.93	6260	3.22	8070	3.48	10220	3.71	12740	3.91	15680	4.07	
MTZ056	45	1730	2.04	2620	2.43	3710	2.81	5060	3.17	6710	3.51	8690	3.83	11060	4.11	13840	4.36	17090	4.57	
MTZ064	45	2160	2.32	3200	2.83	4480	3.32	6060	3.78	7980	4.20	10300	4.60	13070	4.96	16330	5.28	20150	5.55	
MTZ072	45	2550	2.74	3670	3.25	5080	3.75	6810	4.23	8920	4.69	11450	5.11	14450	5.51	17970	5.87	22050	6.19	
MTZ080	45	3170	3.15	4530	3.85	6170	4.48	8130	5.07	10470	5.61	13230	6.11	16470	6.57	20240	7.01	24580	7.41	
MTZ100	45	3240	4.01	4930	4.80	6960	5.53	9390	6.18	12280	6.76	15700	7.26	19710	7.70	24370	8.06	29760	8.34	
MTZ125	45	4660	5.16	6620	6.02	9060	6.86	12060	7.67	15710	8.44	20080	9.16	25250	9.83	31300	10.44	38310	10.98	
MTZ144	45	5700	6.08	8060	7.05	10920	8.00	14370	8.91	18490	9.78	23380	10.60	29110	11.36	35770	12.06	43450	12.69	
MTZ160	45	6280	6.80	8870	7.95	12010	9.04	15790	10.08	20310	11.08	25640	12.05	31900	13.01	39160	13.97	47540	14.95	
MTZ200	45	6480	8.02	9860	9.60	13920	11.05	18770	12.36	24560	13.52	31400	14.53	39420	15.39	48750	16.11	59510	16.68	
MTZ250	45	9320	10.32	13230	12.05	18110	13.73	24120	15.34	31420	16.88	40160	18.32	50500	19.66	62600	20.88	76620	21.96	
MTZ288	45	11410	12.17	16120	14.11	21840	16.00	28740	17.82	36990	19.56	46760	21.20	58220	22.72	71550	24.12	86900	25.37	
MTZ320	45	12550	13.61	17740	15.90	24030	18.08	31590	20.15	40610	22.15	51280	24.10	63790	26.03	78330	27.95	95070	29.90	

Legenda: **To:** Temperatura di evaporazione in °C **Qo:** Capacità di raffreddamento in W Surriscaldamento = 10 K Tensione: 400 V / 3 / 50 Hz
Tc: Temperatura di condensazione in °C **Pe:** Potenza assorbita in kW in kW Sottoraffreddamento = 0 K

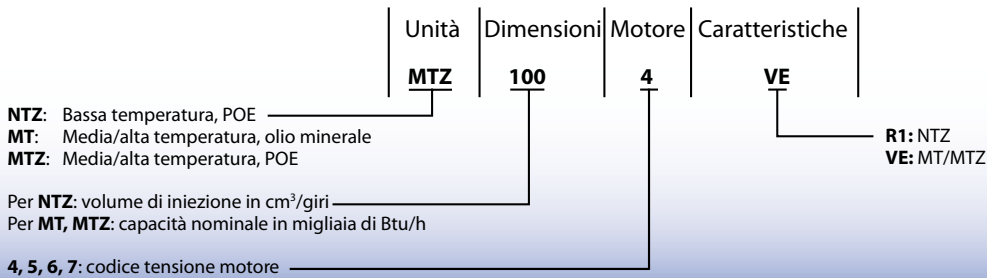

Compressori alternativi – per applicazioni commerciali

Modello	4	5	6	7	Volume di iniezione cm ³ /giro	Cilindrata m ³ /h a 2.900 giri/min.	Numero cilindro	Carica olio dm ³	Peso netto kg	
	460/3/60 400/3/50	230/1/50	230/3/50	575/3/60 500/3/50						
Contropressione bassa Applicazioni	NTZ048	120F0001	120F0087		48	8.4	1	0.95	21	
	NTZ068	120F0002	120F0088		68	11.8	1	0.95	23	
	NTZ096	120F0003			96	16.7	2	1.8	35	
	NTZ108	120F0004			108	18.7	2	1.8	35	
	NTZ136	120F0005			136	23.6	2	1.8	35	
	NTZ215	120F0006			215	37.5	4	3.9	62	
	NTZ271	120F0007			271	47.3	4	3.9	64	
	NTZ430	120F0024			2 x 215	2 x 37.5	2 x 4	2 x 3.9	138	
	NTZ542	120F0025			2 x 271	2 x 47.3	2 x 4	2 x 2.9	142	
Applicazioni contropressione medio-bassa	MT018	MT18-4VI	MT18-5VI		30	5.3	1	0.95	21	
	MT022	MT22-4VI	MT22-5VI	MT22-6VI	38	6.6	1	0.95	21	
	MT028	MT28-4VI	MT28-5VI	MT28-6VI	48	8.4	1	0.95	23	
	MT032	MT32-4VI	MT32-5VI	MT32-6VI	54	9.4	1	0.95	24	
	MT036	MT36-4VI	MT36-5VI	MT36-6VI	60	10.5	1	0.95	25	
	MT040	MT40-4VI		MT40-6VI	68	11.8	1	0.95	26	
	MT044	MT44-4VI		MT44-6VI	76	13.3	2	1.8	35	
	MT050	MT50-4VI	MT50-5VI	MT50-6VI	MT50-7VI	86	14.9	2	1.8	35
	MT056	MT56-4VI		MT56-6VI	MT56-7VI	96	16.7	2	1.8	37
	MT064	MT64-4VI		MT64-6VI		108	18.7	2	1.8	37
	MT072	MT72-4VI		MT72-6VI		121	21.0	2	1.8	40
	MT080	MT80-4VI		MT80-6VI		136	23.6	2	1.8	40
	MT100	MT100-4VI		MT100-6VI	MT100-7VI	171	29.8	4	3.9	60
	MT125	MT125-4VI		MT125-6VI	MT125-7VI	215	37.5	4	3.9	64
	MT144	MT144-4VI		MT144-6VI	MT144-7VI	242	42.1	4	3.9	67
	MT160	MT160-4VI		MT160-6VI	MT160-7VI	272	47.3	4	3.9	69
	MTM200	MTM200T4SA		MTM200T6SA		2 x 171	2 x 29.8	2 x 4	2 x 3.9	134
	MTM250	MTM250T4SA		MTM250T6SA		2 x 215	2 x 37.5	2 x 4	2 x 3.9	142
	MTM288	MTM288T4SA		MTM288T6SA		2 x 242	2 x 42.1	2 x 4	2 x 3.9	148
	MTM320	MTM320T4SA		MTM320T6SA		2 x 272	2 x 47.3	2 x 4	2 x 3.9	152
	MTZ018	MTZ18-4VI	MTZ18-5VI	MTZ18-6VI		30	5.3	1	0.95	21
	MTZ022	MTZ22-4VI	MTZ22-5VI	MTZ22-6VI		38	6.6	1	0.95	21
	MTZ028	MTZ28-4VI	MTZ28-5VI	MTZ28-6VI		48	8.4	1	0.95	23
	MTZ032	MTZ32-4VI	MTZ32-5VI	MTZ32-6VI	MTZ32-7VI	54	9.4	1	0.95	24
	MTZ036	MTZ36-4VI	MTZ36-5VI	MTZ36-6VI	MTZ36-7VI	60	10.5	1	0.95	25
	MTZ040	MTZ40-4VI		MTZ40-6VI		68	11.8	1	0.95	26
	MTZ044	MTZ44-4VI		MTZ44-6VI	MTZ44-7VI	76	13.3	2	1.8	35
	MTZ050	MTZ50-4VI	MTZ50-5VI	MTZ50-6VI	MTZ50-7VI	86	14.9	2	1.8	35
	MTZ056	MTZ56-4VI		MTZ56-6VI	MTZ56-7VI	96	16.7	2	1.8	37
	MTZ064	MTZ64-4VI		MTZ64-6VI		108	18.7	2	1.8	37
	MTZ072	MTZ72-4VI		MTZ72-6VI		121	21.0	2	1.8	40
	MTZ080	MTZ80-4VI		MTZ80-6VI		136	23.6	2	1.8	40
MTZ100	MTZ100-4VI		MTZ100-6VI	MTZ100-7VI	171	29.8	4	3.9	60	
MTZ125	MTZ125-4VI		MTZ125-6VI	MTZ125-7VI	215	37.5	4	3.9	64	
MTZ144	MTZ144-4VI		MTZ144-6VI	MTZ144-7VI	242	42.1	4	3.9	67	
MTZ160	MTZ160-4VI		MTZ160-6VI	MTZ160-7VI	272	47.3	4	3.9	69	
MTZ200	MTZ200T4SA		MTZ200T6SA		2 x 171	2 x 29.8	2 x 4	2 x 3.9	134	
MTZ250	MTZ250T4SA		MTZ250T6SA		2 x 215	2 x 37.5	2 x 4	2 x 3.9	142	
MTZ288	MTZ288T4SA		MTZ288T6SA		2 x 242	2 x 42.1	2 x 4	2 x 3.9	148	
MTZ320	MTZ320T4SA		MTZ320T6SA		2 x 272	2 x 47.3	2 x 4	2 x 3.9	152	

Dimensioni

**MT / MTZ / NTZ
1 cilindro**

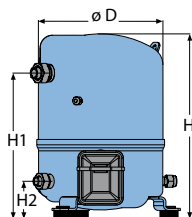

D : 224 mm
H : 333/358 mm
H1 : 263 mm
H2 : 68 mm

**MT / MTZ / NTZ
2 cilindri**

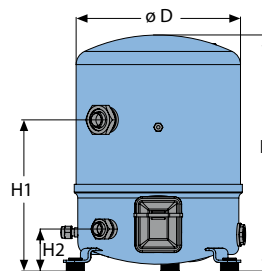

D : 288 mm
H : 413 mm
H1 : 265 mm
H2 : 74 mm

**MT / MTZ / NTZ
4 cilindri**

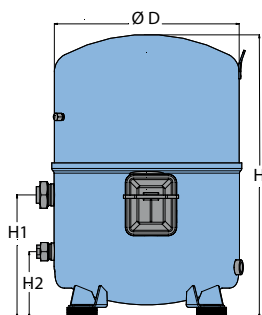

D : 352 mm
H : 519/540 mm
H1 : 233 mm
H2 : 125 mm

**MT / MTZ / NTZ Tandem
2 x 4 cilindri**

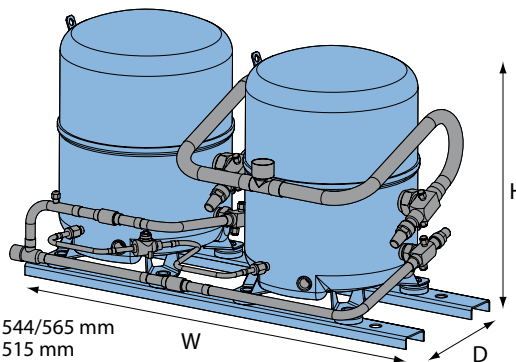

H : 544/565 mm
D : 515 mm
W : 925 mm